

One Piece solid shaft Vertical Sump Pumps

GV



Applications

- 배수용 Sump Drainage
- 오수처리용 Sewage treatment
- 일반 산업용 General industry

Feature

- ☑ 스테인레스 강재의 단일축
Heavy duty one-piece solid shaft
- ☑ 단순한 구조의 쉬운 유지보수
Simple construction for easy maintenance interchangeability
- ☑ 완전표준화에 의한 최대의 호환성
Completely standardization for high interchangeability
- ☑ 프라임 및 푸트 밸브 불필요
Not need priming and foot valve
- ☑ 튼튼하고 견고한 구조
Rugged, heavy duty construction

Ratings

Capacity	Up to 0.7 m ³ /min (184 US GPM)
Head	Up to 30m (98ft)
Revolution 60Hz	1750 min ⁻¹
Rotation	Clockwise (viewed from coupling end)
Temperature	~60°C (140°F)
Nozzle Rating	KS 10 Kgf/cm ² - FF
Nozzle Location	Side Discharge
Max. Pump length	1.8m (5.9ft)

Specification

구분 규격	POWER	CAPACITY / HEAD					
		유량(m /min)	양정(m)	유량(m /min)	양정(m)	유량(m /min)	양정(m)
GV5015	0.75 1.5	0.1 0.1	9 15	0.2 0.2	7 13.5	0.3 0.33	4 10
GV5023	2.2	0.1	22	0.2	20	0.35	15
GV6516	2.2	0.2	11	0.3	10	0.4	8
GV6526	2.2 3.7	0.2 0.2	16.5 23.5	0.3 0.4	15 20	0.45 0.5	12.5 18
GV8015	2.2 3.7	0.3 0.3	10 19	0.45 0.5	9 17	0.6 0.7	8 14
GV8023	5.5	0.3	23	0.6	20	0.8	16

참고: *, 이 카탈로그의 내용은 예고없이 변경 될 수 있습니다.

Installation Dimension

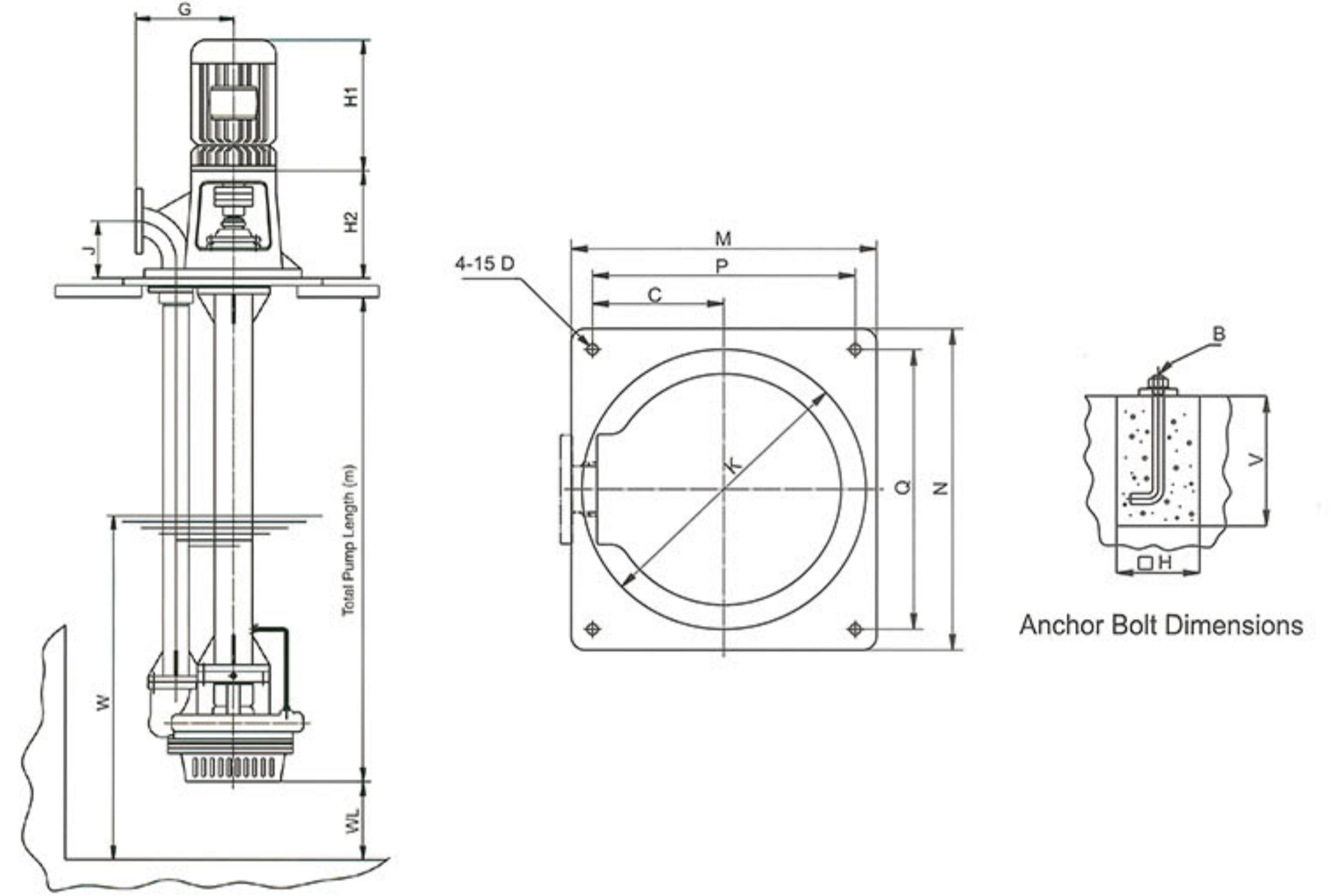

구분 규격	Pump and motor								Baseplate						Anchor Bolt		
	Frame	kW	H1	H2	WL	G	J	W	M	P	C	Q	N	K	B	H	V
5023	112S	2.2	315	253	100	230	130	370	430	370	185	400	460	400	4-M12×200L	120	200
6526	112M	3.7	340	265	100	240	160	370	450	390	205	420	490	420	4-M12×200L	120	200
8023	132S	5.5	382	265	100	250	160	370	450	390	205	440	490	420	4-M12×200L	120	200

참고: *, 단위: mm / 이 카탈로그의 내용은 예고없이 변경 될 수 있습니다.

Parts List and Materials

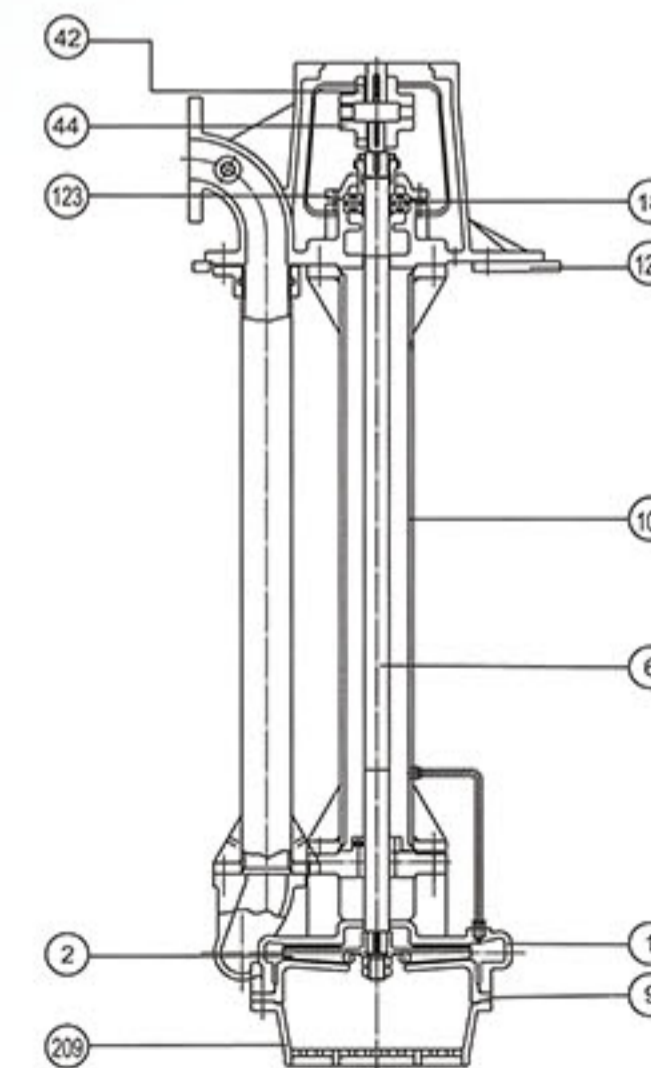

No	Name of part	MATERIAL
1	Casing	GC200
2	Impeller	GC200
6	Shaft	SM45C
9	Suction Cover	GC200
18	Bearing	STEEL
42	Motor Coupling	GC200
44	Pump Coupling	GC200
101	Column Pipe	SPPS38
123	Bearing Cover	GC200
129	Sole Plate	GC200
209	Strainer	GC200

참고: *, 이외의 기타 자료는 요청시 제공됩니다.