

Dual Volute Multi-Stage Pumps

MV

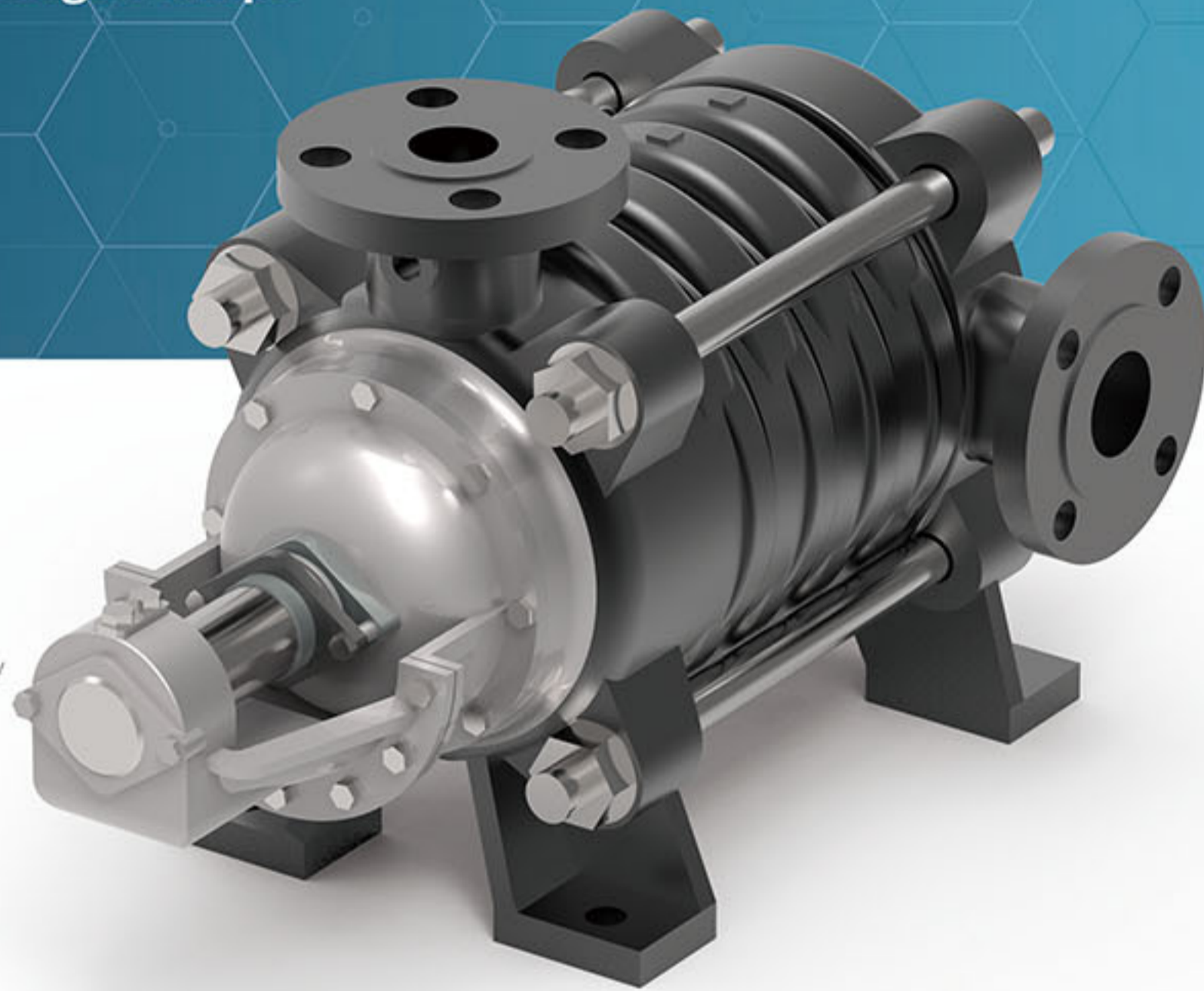

Applications

- 보일러 급수용 Boiler feed
- 가압용 Booster
- 소화설비용 Fire-fighting jockey
- 건물용 Building
- 일반 산업용 General industry

Feature

- ☑ 단순한 구조
Simple construction
- ☑ 고효율, 낮은 NPSHr.
Good efficiency, low NPSHr.
- ☑ 견고한 구조
Heavy and sturdy construction

Ratings

Capacity	UP to 3m ³ /min (792 US GPM)
Head	UP to 140m (459ft)
Temperature	UP to 90°C (194°F)

Specification

Stage Power
2 / 37
1750 RPM

H(m)	15	18	22	26	30	40	50	60	70	80	90	100	120	140	160	180
140m																
135																
130																
125																
120																
115																
110																
105																
100																
95																
90																
85																
80																
75																
70																
65																
60																
55																
50																
45																
40																
35																
30																
28																
26																
24																
22																
20																
H(m)	15	18	22	26	30	40	50	60	70	80	90	100	120	140	160	180
Size (mm)	Ø50	Ø65	Ø80	Ø100	Ø125	Ø150										

Installation Dimension

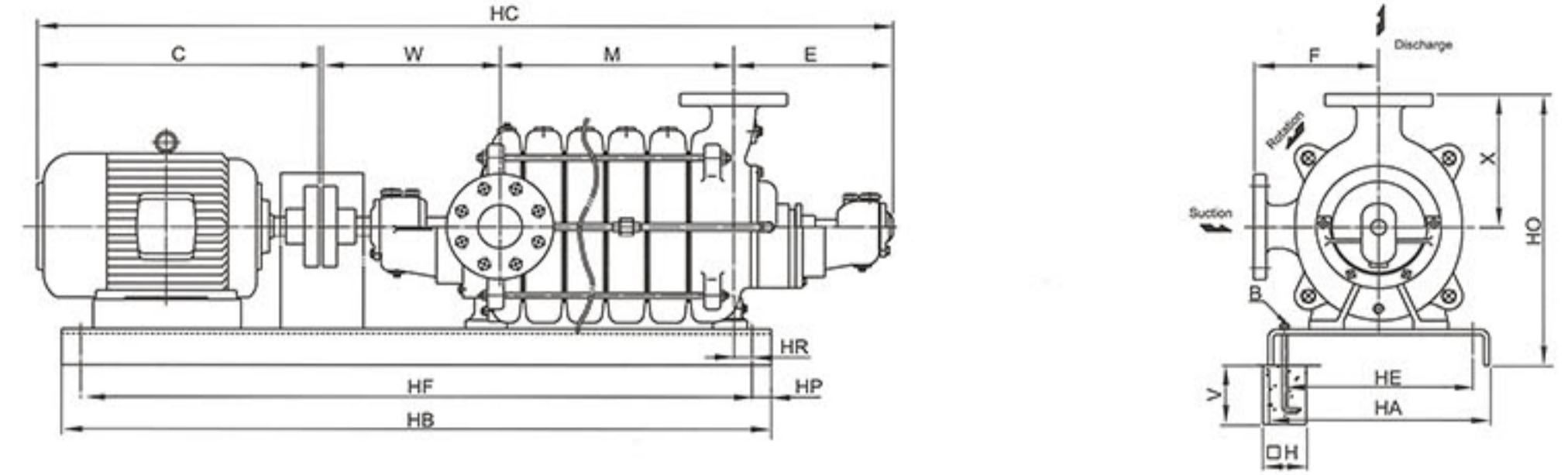

구분 규격	Pump and motor										Baseplate						Anchor Bolt				
	Suc	Dis	Frame	kW	HC	C	W	M	E	F	X	HR	HF	HB	HP	HO	HE	HA	B	H	V
502	50	50	112S	2.2	1017	356	255	158	243	180	195	75	750	800	25	405	215	265	4-M16x400L	150	400
503	50	50	112M	3.7	1103	382	255	218	243	180	195	40	850	900	25	405	215	265	4-M16x400L	150	400
504	50	50	132S	5.5	1225	444	255	278	243	180	195	40	950	1000	25	405	255	305	4-M16x400L	150	400
505	50	50	132M	7.5	1323	482	255	338	243	180	195	40	1000	1050	25	405	255	305	4-M16x400L	150	400
506	50	50	132M	7.5	1383	482	255	398	243	180	195	40	1100	1150	25	405	255	305	4-M16x400L	150	400
507	50	50	160M	11	1554	593	255	458	243	180	195	40	1250	1300	25	430	305	355	4-M16x400L	150	400
508	50	50	160M	11	1614	593	255	518	243	180	195	40	1300	1350	25	430	305	355	4-M16x400L	150	400
652	65	65	132S	5.5	1202	444	300	176	277	200	210	90	900	950	25	440	255	305	4-M16x400L	150	400
653	65	65	123M	7.5	1311	482	300	247	277	200	210	90	950	1000	25	440	255	305	4-M16x400L	150	400
654	65	65	160M	11	1493	593	300	318	277	200	210	50	1150	1200	25	455	305	355	4-M16x400L	150	400
655	65	65	160M	11	1564	593	300	389	277	200	210	50	1200	1250	25	455	305	355	4-M16x400L	150	400
656	65	65	160L	15	1679	637	300	460	277	200	210	50	1350	1400	25	455	305	355	4-M20x500L	150	500
657	65	65	180M	19	1760	647	300	531	277	200	210	50	1400	1450	25	465	350	400	4-M16x400L	150	400
802	80	80	132M	7.5	1205	482	262	198	258	210	210	80	950	1000	25	450	255	305	4-M16x400L	150	400
803	80	80	160M	11	1386	593	262	268	258	210	210	40	1050	1100	25	450	305	355	4-M16x400L	150	400
804	80	80	160L	15	1500	637	262	338	258	210	210	40	1150	1200	25	465	305	355	4-M16x400L	150	400
805	80	80	180L	22	1618	685	262	408	258	210	210	40	1250	1300	25	465	350	400	4-M16x400L	150	400
806	80	80	180L	22	1698	685	272	478	258	210	210	40	1350	1400	25	465	350	400	4-M20x500L	150	500
807	80	80	200M	30	1791	708	272	548	258	210	210	40	1450	1500	25	485	390	440	4-M20x500L	150	500
102	100	100	160L	15	1518	637	325	225	326	250	270	80	1150	1200	25	555	305	355	4-M16x400L	150	400
103	100	100	180L	22	1651	685	325	310	326	250	270	80	1300	1350	25	555	350	400	4-M16x400L	150	400
104	100	100	200M	30	1759	708	325	395	326	250	270	40	1350	1400	25	555	390	440	4-M20x500L	150	500
105	100	100	200L	37	1883	747	325	480	326	250	270	40	1452	1500	25	555	390	440	4-M20x500L	150	500

참고: *. 단위: mm,inch / 이 카탈로그의 내용은 예고없이 변경 될 수 있습니다.

Parts List and Materials

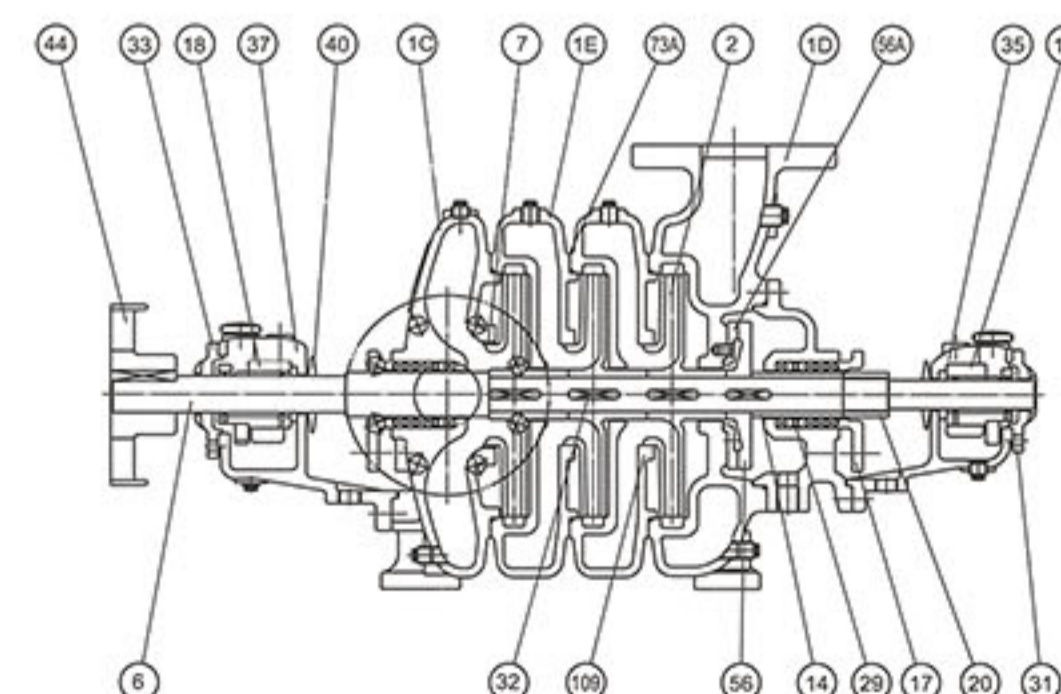

No	Name of part	MATERIAL	No	Name of part	MATERIAL
1C	Suct. Casing	GC200	31	Inboard Housing	GC200
1D	Dis. Casing	GC200	32	Impeller Key	SM45C
1E	Stage Casing	GC200	33	Outboard Housing	GC200
2	Impeller	BC6	35	In Bear. Cover	GC200
6	Shaft	SM45C	37	Out Bear. Cover	GC200
7	Casing Ring	BC6	40	Deflector	NBR
14	Sleeve	BC6	44	Pump Coupling	GC200
16	Inboard Bear.	WHITE METAL	56	Balance Disk	BC6
17	Packing Gland	GC200	56A	Balance Seal	BC6
18	Outboard Bear.	WHITE METAL	60	Oil Ring	BC6
20	Sleeve Nut	BC6	73A	Casing Gasket	NBR
29	Lantern Ring	TEFLON	83	Stuffing Box	GC200

참고: *. 이외의 기타 자료는 요청시 제공됩니다.