

Horizontal Screw Pumps

SC



Applications

- 폐수처리 Waste treatment
- 식품이송 Food transfer
- 고농도제지액 Paper stock

Feature

- ☑ 비닐이나 섬유류등에 영김이 없음
No tangles in vinyl or fibers
- ☑ 고효율, 낮은 NPSHr.
High efficiency, low NPSHr.
- ☑ 고농도 펄프액, 오니의 이송에 적합
Suitable for transferring high concentration pulp liquid and sludge
- ☑ 양정의 변화에 대한 유량의 변화가 적어 유량제어 용이
It is easy to control the flow rate because there is little change in the flow rate relative to the change of the head

Ratings

Capacity	0.2~30 m ³ /min (52 ~ 7,925 US GPM)	Temperature	~80°C (176°F)
Head	3~30m (9.8ft~98ft)	Nozzle Rating	KS 10 Kgf/cm ² - FF
Discharge Pressure	Up to 10 kgf/cm ² (142 PSIG)	Nozzle Location	End Suction : Top Discharge
Revolution 60Hz	1750 min ⁻¹ & pully type	Seals	Conventional Packing or Mechanical Seal
Rotation	Clockwise (viewed from coupling end)		

Mixed liquid specific gravity

* 일반적으로 사용되는 범위

혼합농도(%) 분배비율	5%	10%	15%	20%	25%	30%	40%	50%
1.5	1.03	1.05	1.08	1.10	1.13	1.15	1.20	1.25
* 2.0	1.02	1.03	1.05	1.07	1.09	1.11	1.15	1.2
	1.05	1.10	1.15	1.20	1.25	1.30	1.40	1.5
	1.03	1.05	1.08	1.11	1.14	1.13	1.25	1.33
* 2.5	1.08	1.15	1.23	1.30	1.38	1.45	1.60	1.75
	1.03	1.06	1.10	1.14	1.18	1.22	1.32	1.43
* 3.0	1.10	1.20	1.30	1.40	1.50	1.60	1.80	2.0
	1.03	1.07	1.11	1.15	1.20	1.25	1.36	1.5
	1.14	1.25	1.38	1.50	1.63	1.75	2.0	2.25
3.5	1.04	1.08	1.12	1.17	1.22	1.27	1.44	1.56
	1.14	1.30	1.45	1.60	1.75	1.90	2.2	2.5
4.0	1.08	1.08	1.13	1.18	1.23	1.29	1.43	1.6
	1.18	1.35	1.53	1.70	1.88	2.05	2.4	2.75
4.5	1.04	1.08	1.13	1.18	1.24	1.30	1.45	1.64
	1.24	1.40	1.60	1.80	2.0	2.20	2.6	3.0
5.0	1.05	1.09	1.14	1.19	1.25	1.32	1.47	1.67
	1.25	1.50	1.75	2.0	2.25	2.50	3.0	-
6.0	1.04	1.09	1.14	1.2	1.26	1.33	1.5	1.71
	1.30	1.60	1.90	2.2	2.50	2.80	-	-
7.0	1.04	1.09	1.15	1.21	1.27	1.35	1.52	1.75
	1.35	1.70	2.05	2.4	2.75	-	-	-
8.0	1.05	1.10	1.15	1.21	1.28	1.36	1.54	1.78

Installation Dimension

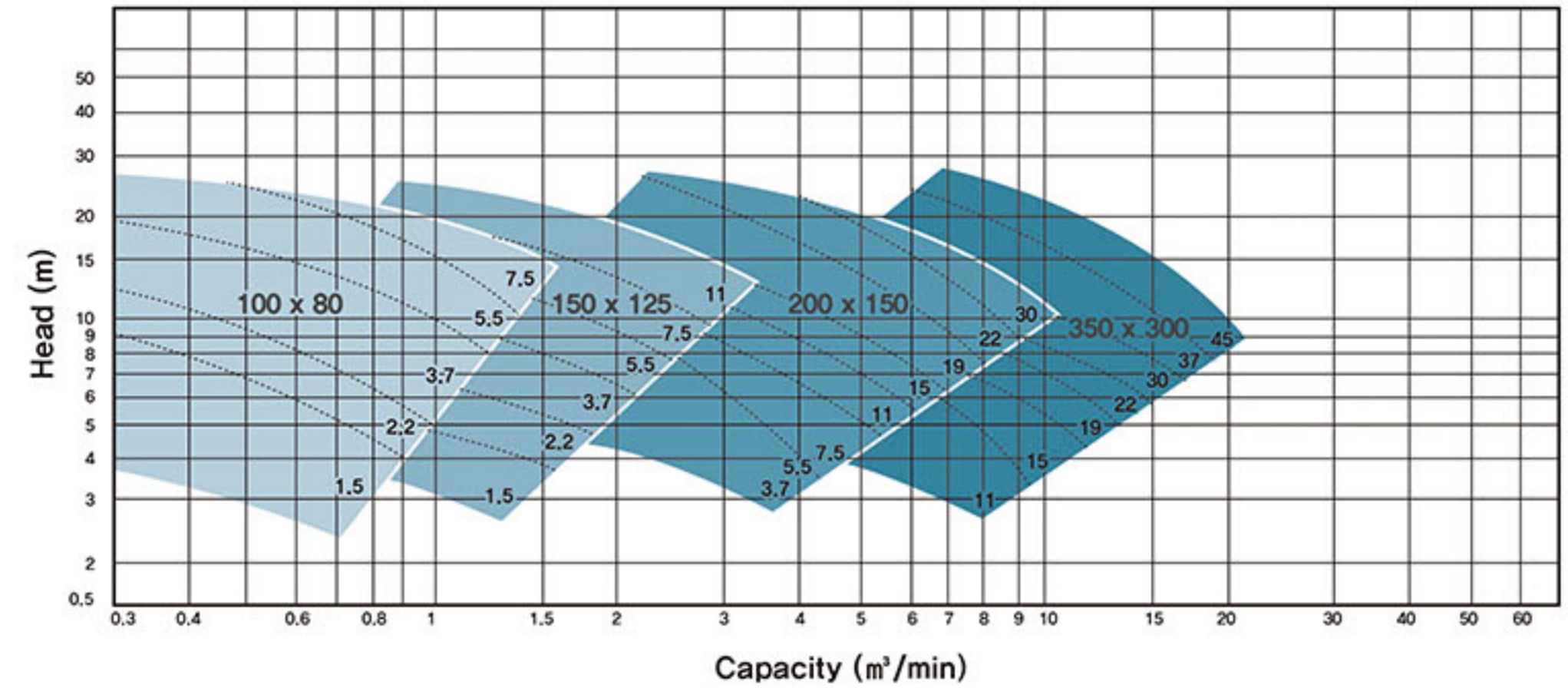

Parts List and Materials

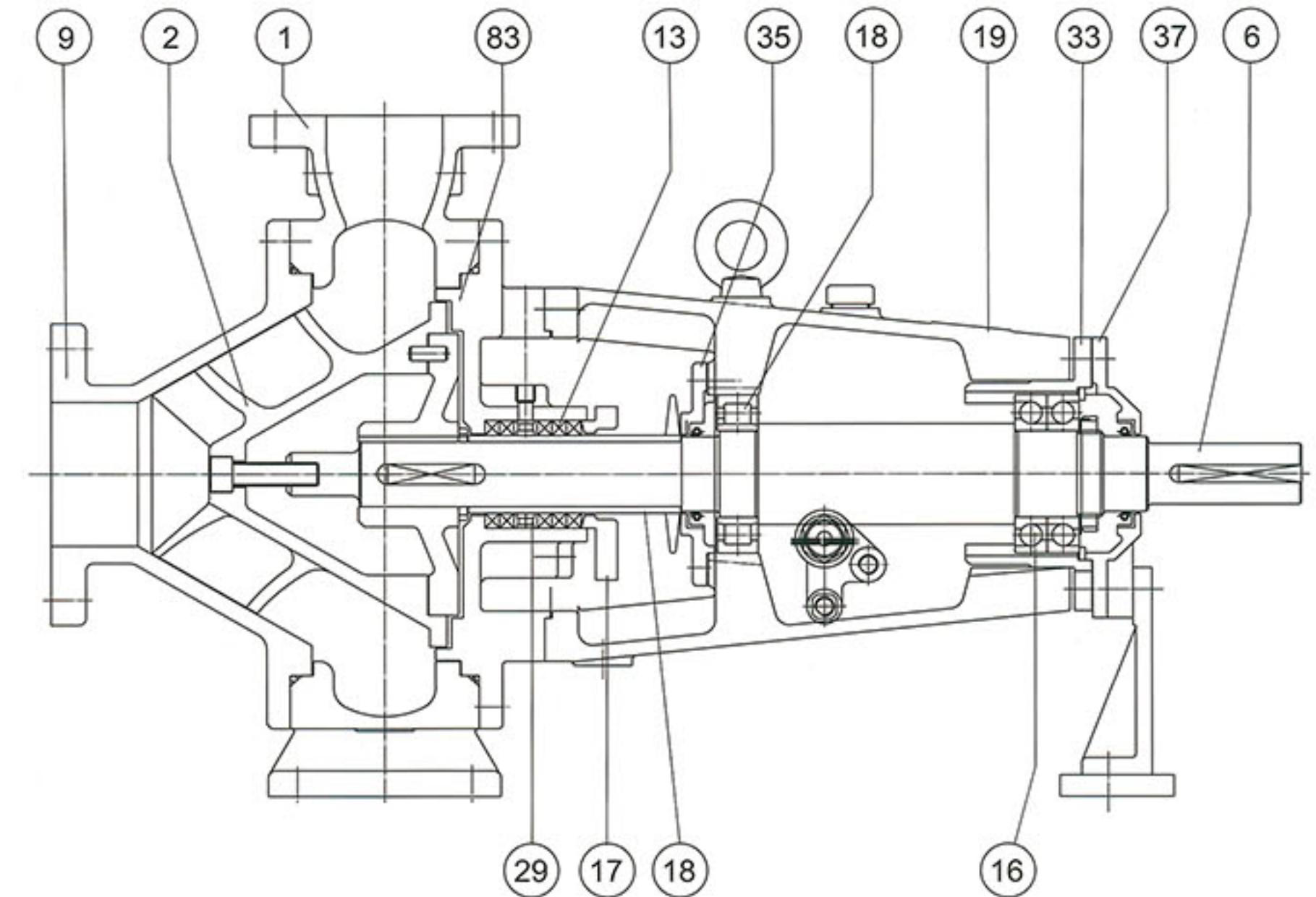

No	Name of part	METERIAL	No	Name of part	METERIAL
1	Casing	GC200 SSC13	17	Packing Gland	GC200 SSC13
2	Impeller	SSC13 SSC13	18	Inboard Bearing	STEEL STEEL
6	Shaft	SM45C STS304	19	Frame	GC200 GC200
9	Suction Cover	GC200 SSC13	29	Lantern Ring	BC6 SSC13
13	Packing	TEFLON TEFLON	33	Bearing Housing	GC200 GC200
14	Shaft Sleeve	BC6 STS304	35	Inboard Bearing Cover	GC200 GC200
16	Outboard Bearing	STEEL STEEL	37	Outboard Bearing Cover	GC200 GC200
			83	Stuffing Box	GC200 SSC13

참고: * 이외의 기타 자료는 요청시 제공됩니다.