

## Double Suction Pumps Multi Stage Type

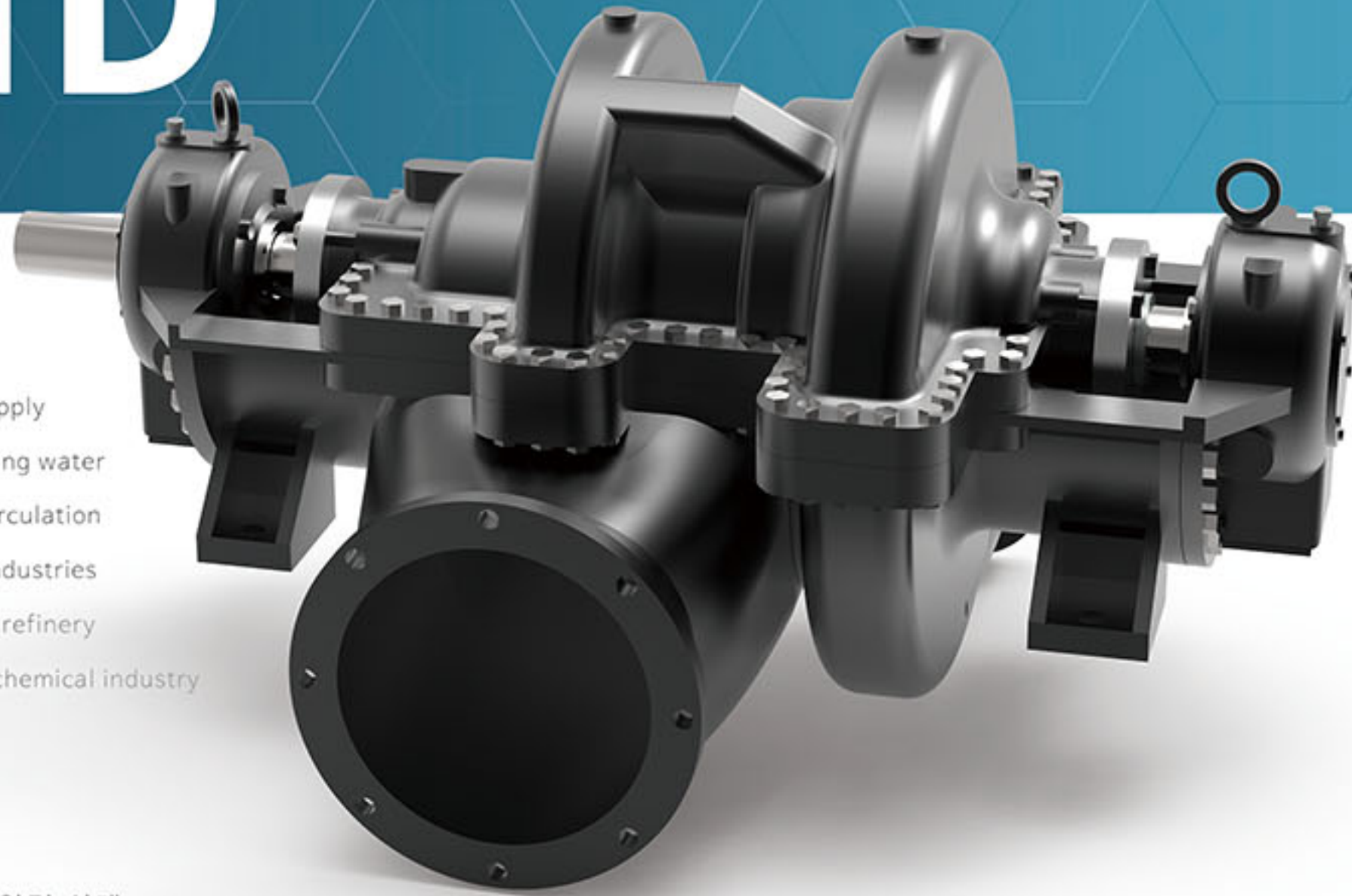

# SMD



### Applications

- 급수, 정수용 Water Supply
- 냉각수용 Utilities cooling water
- 보일러 순환용 Boiler circulation
- 일반 산업용 General Industries
- 석유정제용 Petroleum refinery
- 석유화학공업용 Petrochemical industry

### Feature

- ☑ 향상된 용량 및 높은 압력 설계  
Improved capacity and high pressure
- ☑ 축 밸런스 보장 : 수명이 길고 유지 보수가 쉬움  
Assures axial balance : long-life, low-maintenance cost
- ☑ 고효율, 견고하고 견고한 구조  
High efficiency, Heavy and sturdy construction
- ☑ 완전한 표준화를 통해 광범위한 적용  
Completely standardization for wide application
- ☑ API standard 610 적용 (API Code : BB3)  
API standard 610 (API Code : BB3)

### Ratings

Capacity	Up to 35m <sup>3</sup> /min (9,246 US GPM)
Head	Up to 400m (1,312ft)
Discharge Pressure	Up to 60 kgf/cm <sup>2</sup> (853 PSIG)
Allowable Suction Pressure	Up to 20 kgf/cm <sup>2</sup> (284 PSIG)
Impeller	Enclosed
Temperature	-50°C ~ 150°C (-58°F ~ 302°F)
Flanges	ANSI, other standards also available
Materials	According to API 610 Material code

\*API 610 최신 버전은 요청에 따라 적용할 수 있습니다.



### Design drawing

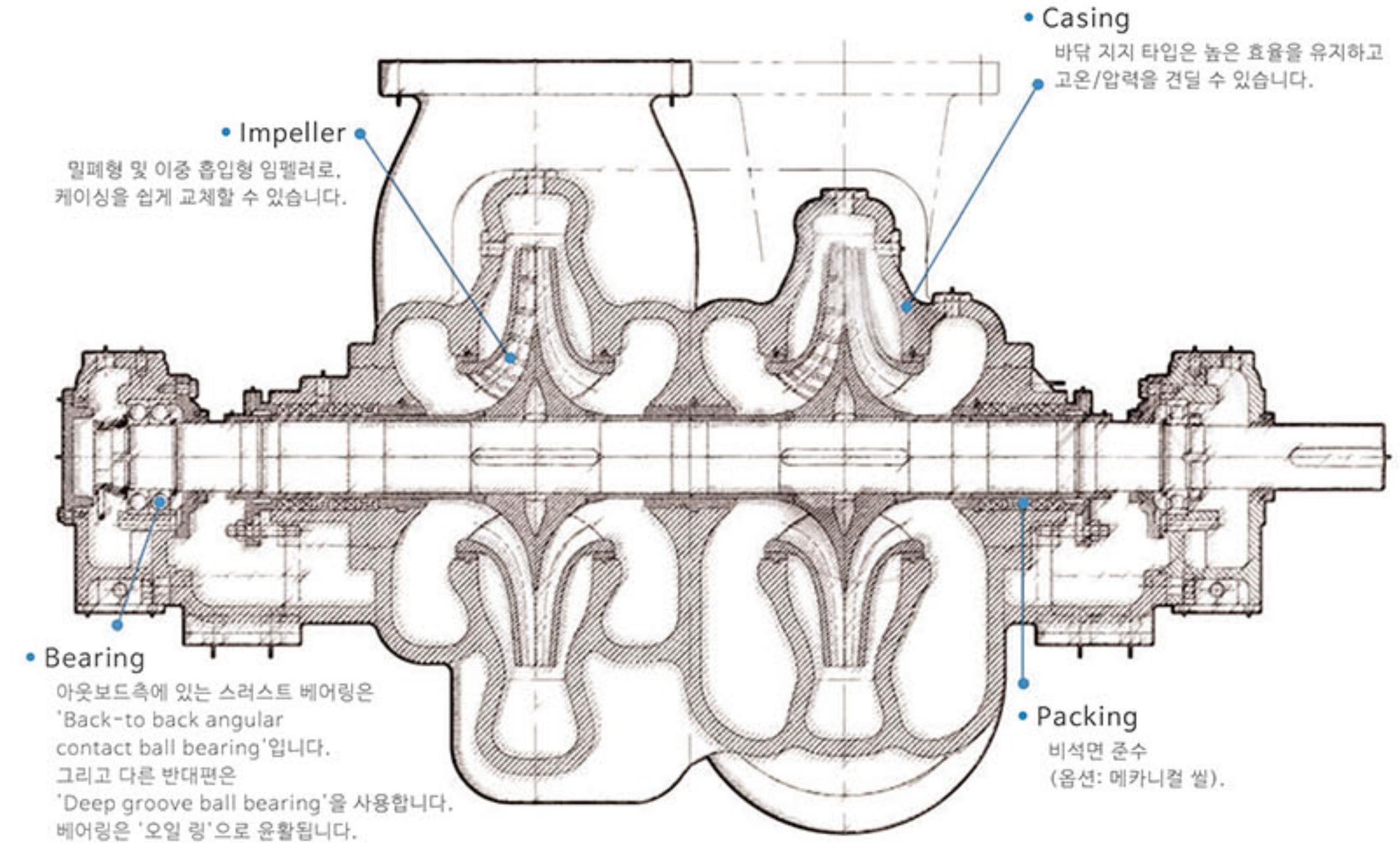

### Photo Resources

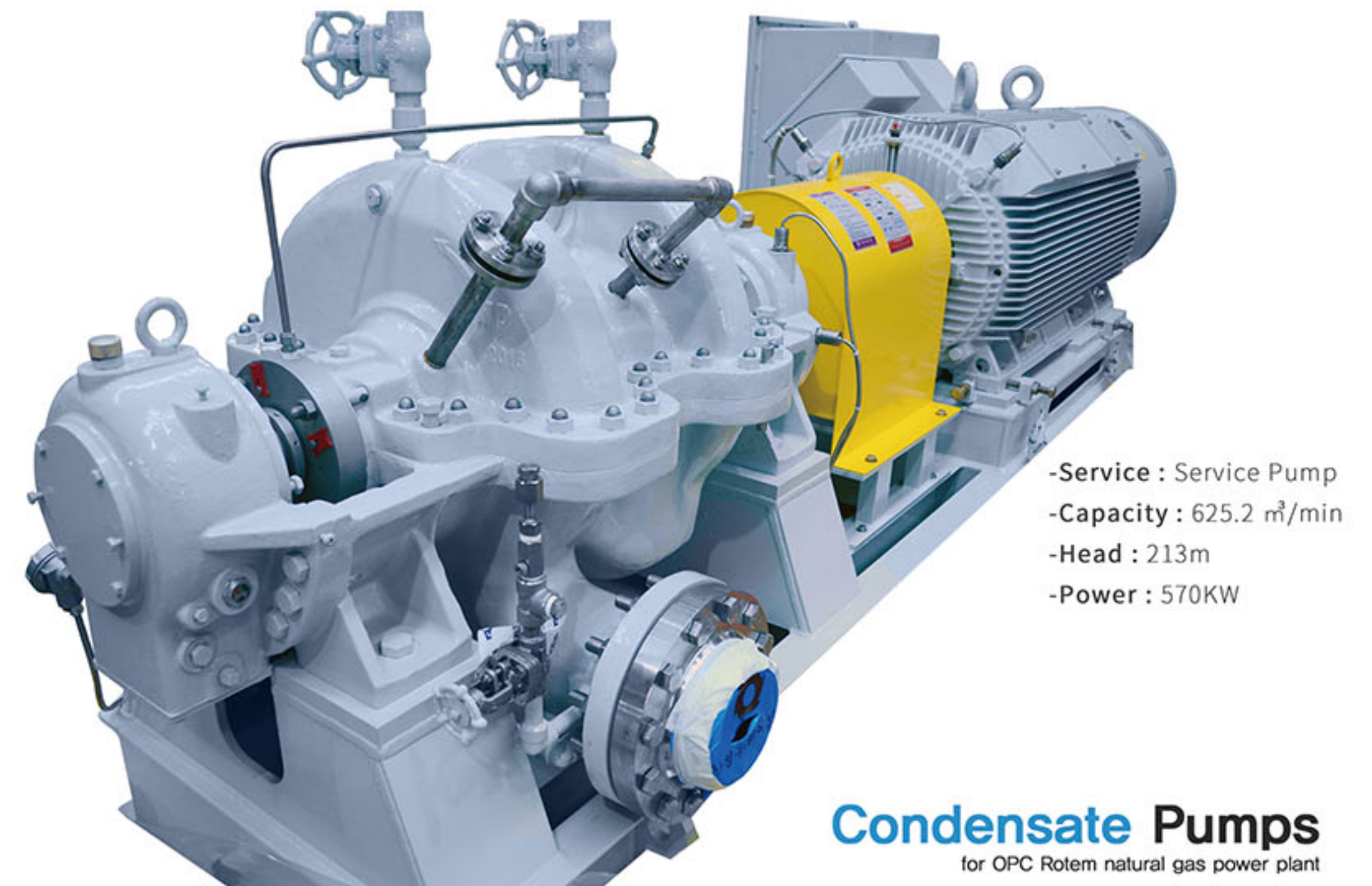

**Condensate Pumps**  
for OPC Rotem natural gas power plant